

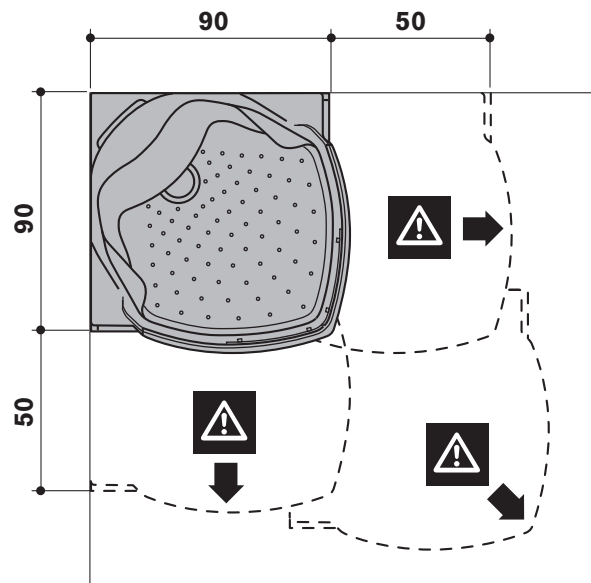

Allegare ai testi di pag.3 e 4 • This sheet to be with texts on pages 5 and 6
 Fiche à associer aux textes des pages 7 et 8 • Dieses Datenblatt muß vom Text von S.9-10
 Ficha a unirse a textos pág.11 y 12 • Esta ficha com textos pág.13 e 14

FlexaThema

SQUARE

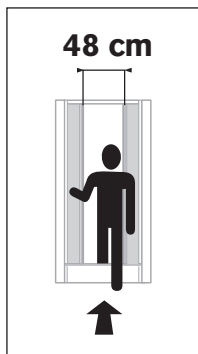
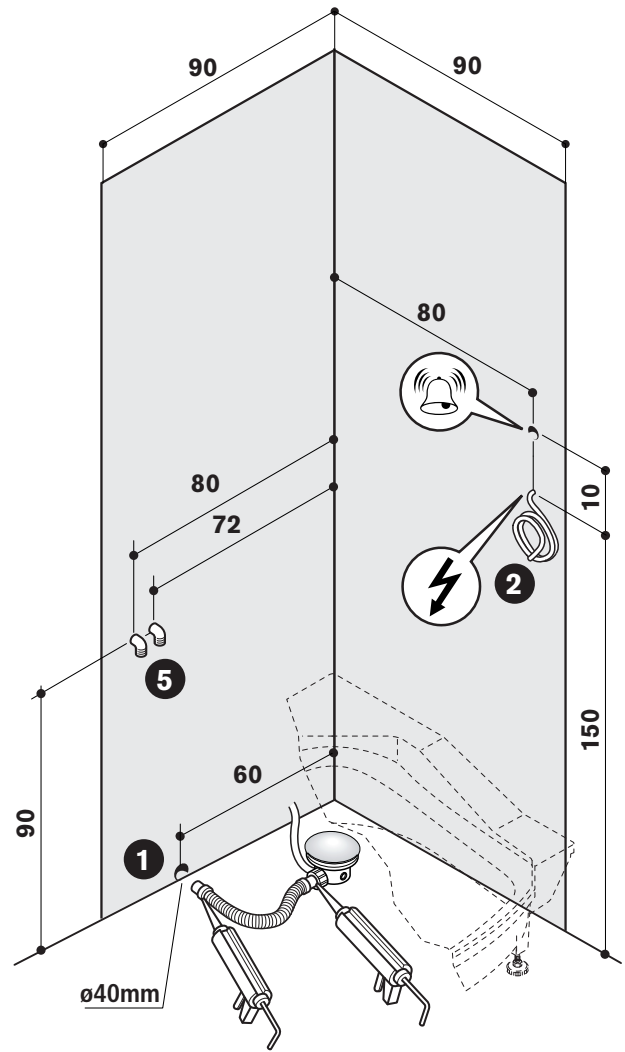
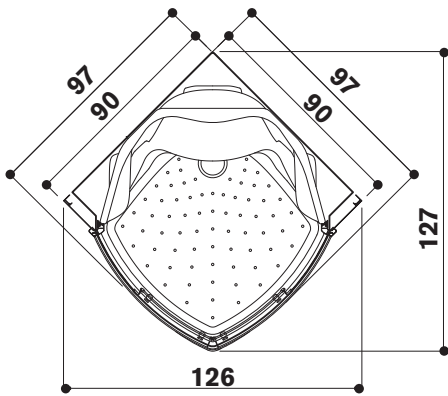
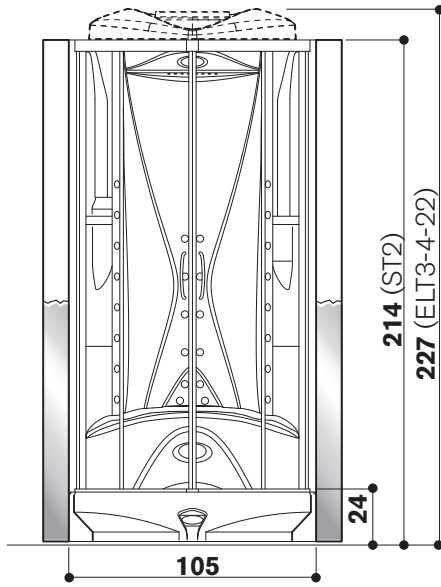

ZONA LIBERA • ACCESS SPACE
BANDE LIBRE • FREIRAUM
ESPACIO LIBRE • ESPAÇO LIVRE





CARATTERISTICHE IDRAULICHE • HYDRAULIC SPECIFICATIONS • CARACTERISTIQUES HYDRAULIQUES
HYDRAULIK-ANGABEN • CARACTERISTICAS HIDRAULICAS • CARACTERÍSTICAS HIDRÁULICAS

PRESSIONE DI ESERCIZIO • OPERATING PRESSURE • PRESSION DE SERVICE
 BETRIEBSDRUCK • PRESIÓN DE FUNCION. • PRESSÃO DE FUNCIONbar

PRESSIONE OTTIMALE • OPTIMUM PRESSURE • PRESSION OPTIMAL
 OPTIMALER WASSERDRUCK • PRESIÓN ÓPTIMAL • PRESSÃO OPTIMALbar

CONSUMO D'ACQUA • WATER CAPACITY • CONSOMMATION D'EAU
 WASSERVERBRAUCH • CONSUMO DE AGUA • CONSUMO DE ÁGUA.....l/min (MAX)

BOCCHETTE IDRO • WHIRLPOOL FITTINGS • BUSES HYDROMASSAGE
 ANZAHL MASSAGEDÜSEN • BOQUILLAS HIDROMASAJE • JACTOS DE HIDROMASSAGEM

COLLEGAMENTI • CONNECTIONS • RACCORDEMENTS
ANSCHLÜSSE • CONEXIONES • CONEXÃO

ACQUA CALDA/FREDDA • HOT/COLD WATER • EAU CHAUDE/FROIDE
 KALT/WARMWASSER • AGUA CALIENTE/FRIA • AGUA QUENTE/FRIA.....Ø

SCARICO A PARETE • WALL DRAINAGE • ÉCOULEMENT AU SOL
 ABFLUBROHR AM BODEN • DESAGUADERO EN SUELO • DESCARGA NO PAVIMENTO.....Ø

ST2	ELT3	ELT4	ELT22
•	•	•	•
2÷3	2÷3	2÷3	2÷3
14⁽¹⁾	13⁽²⁾	13⁽²⁾	13⁽²⁾
8 + 4	16 + 4	16 + 8	16 + 8
1/2"	1/2"	1/2"	1/2"
40 mm	40 mm	40 mm	40 mm

• min 1,5 - max 5 (min 21 psi - max 70 psi / 150 kPa min - 500 kPa max)

- (1) idrogetti (a 2,5 bar) • hydro-nozzles (at 2,5 bar) • buses hydro (à 2,5 bar) • Massagedüsen (hat 2,5 bar) • boquillas de hidro (a 2,5 bar) • bocas hidro (a 2,5 bar)
 (2) soffione doccia (a 2,5 bar) • shower head (at 2,5 bar) • pomme de douche (à 2,5 bar)
 Kopfbrause (hat 2,5 bar) • rociador de la ducha (a 2,5 bar) • chuveiro duche (a 2,5 bar)

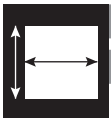

CARATTERISTICHE DIMENSIONALI • WEIGHT AND DIMENSIONS • DIMENSIONS & POIDS
MASSE UND GEWICHTE • CARACTERISTICAS DIMENSIONALES • DIMENSÕES E PESOS

LxWxH cm

PESO NETTO • NET WEIGHT • POIDS NET • NETTOGEW. • NETO • LÍQUIDO~ kg

PESO DI SPEDIZIONE • SHIPPING WEIGHT • POIDS À L'EXPÉDITION
 VERSANDGEWICHT • PESO DE EXPEDICIÓN • PESO DE EXPEDIÇÃO~ kg

VOLUME DI SPEDIZIONE • SHIPPING VOLUME • VOLUME À L'EXPÉDITION
 VERSANDVOLUMEN • VOLUMEN DE EXPEDICIÓN • VOLUME DE EXPEDIÇÃO~ m³

IMBALLO • PACKAGE • EMBALLAGE • VERPACKUNG • EMBAL. • EMBAL.cm

ST2	ELT3	ELT4	ELT22
90/97x90/97x214	90/97x90/97x227	90/97x90/97x227	90/97x90/97x227
115	126	126	128
180	191	191	193
3,27	3,27	3,27	3,27
A+B+C_(x)	A+B+C_(x)	A+B+C_(x)	A+B+C_(x)

- (x) A: parete • panele • panneau • Paneel • parede • pared: 206x97x103 - kg 44/81 (ST2) • kg 50/87 (ELT3/4) • kg 52/89 (ELT22)
 B: piatto doccia • shower tray • plateau de douche • Duschwanne • plato de ducha • fundo do ducha: 109x107x38 - kg 15/21 (ST2) • kg 20/26 (ELT3, 4, 22)
 C: cristalli • glasses • vitres • Gläser • cristales • cristais: 222x81x43 - kg 56/78



CARATTERISTICHE ELETTRICHE • ELECTRIC SPECIFICATIONS • CARACTERISTIQUES ELECTRIQUES
ELEKTRO-ANGABEN • CARACTERISTICAS ELECTRICAS • CARACTERÍSTICAS ELÉCTRICAS

VOLTV

HERTZHz

AMPÈRE (BAGNO TURCO) • (STEAM BATH) • (HAMMAM) • (DAMPFBAD) • (BAÑO TURCO) • (BANHO TURCO)A

kW (BAGNO TURCO) • (STEAM BATH) • (BAIN TURC) • (DAMPFBAD) • (BAÑO TURCO) • (BANHO TURCO)kW

ST2	ELT3	ELT4	ELT22
-	220/240	220/240	220/240
-	50	50	50
-	11^(k)	11^(k)	11^(k)
-	2,5^{(j)(k)}	2,5^{(j)(k)}	2,5^{(j)(k)}

(j) potenza assorbita • power absorption • puissance absorbée • Leistungsaufnahme • potencia absorbida • potência absorvida **MAX 2,5 kW**

(k) a 230 V • at 230 V • à 230 V • hat 230 V • a 230 V • a 230 V