

Размеры даны в миллиметрах

ART. B--B----		
Вес нетто, Kg.	Вес в упакованном виде, Kg.	Объем в упакованном виде, m ³
min. 62 - max. 118	min. 64 - max. 186	min. 1 - max. 3,5

		B		
		800	900	1000
A	800	B88B X= 790 (+5/-0) Y=790 (+10/-5)	B89B X= 790 (+5/-0) Y=890 (+10/-5)	B8AB X= 790 (+5/-0) Y=990 (+10/-5)
	900	B98B X= 890 (+10/-5) Y=790 (+10/-5)	B99B X= 890 (+10/-5) Y=890 (+10/-5)	B9AB X= 890 (+10/-5) Y=990 (+10/-5)
	1000	BA8B X= 980 (+10/-5) Y=790 (+10/-5)	BA9B X= 990 (+10/-5) Y=890 (+10/-5)	BAAB X= 990 (+10/-5) Y=990 (+10/-5)
	1100	BB8B X= 1090 (+10/-5) Y=790 (+10/-5)	BB9B X= 1090 (+10/-5) Y=890 (+10/-5)	BBAB X= 1090 (+10/-5) Y=990 (+10/-5)
	1200	BC8B X= 1190 (+10/-5) Y=790 (+10/-5)	BC9B X= 1190 (+10/-5) Y=890 (+10/-5)	BCAB X= 1190 (+10/-5) Y=990 (+10/-5)
	1300	BD8B X= 1290 (+10/-5) Y=790 (+10/-5)	BD9B X= 1290 (+10/-5) Y=890 (+10/-5)	BDAB X= 1290 (+10/-5) Y=990 (+10/-5)
	1400	BE8B X= 1390 (+10/-5) Y=790 (+10/-5)	BE9B X= 1390 (+10/-5) Y=890 (+10/-5)	BEAB X= 1390 (+10/-5) Y=990 (+10/-5)
	1500	BF8B X= 1490 (+10/-5) Y=790 (+10/-5)	BF9B X= 1490 (+10/-5) Y=890 (+10/-5)	BFAB X= 1490 (+10/-5) Y=990 (+10/-5)
	1600	BG8B X= 1590 (+10/-5) Y=790 (+10/-5)	BG9B X= 1590 (+10/-5) Y=890 (+10/-5)	BGAB X= 1590 (+10/-5) Y=990 (+10/-5)
	1700	BH8B X= 1690 (+10/-5) Y=790 (+10/-5)	BH9B X= 1690 (+10/-5) Y=890 (+10/-5)	BHAB X= 1690 (+10/-5) Y=990 (+10/-5)
	1800	BI8B X= 1790 (+10/-5) Y=790 (+10/-5)	BI9B X= 1790 (+10/-5) Y=890 (+10/-5)	BIAB X= 1790 (+10/-5) Y=990 (+10/-5)
	1900	BL8B X= 1890 (+10/-5) Y=790 (+10/-5)	BL9B X= 1890 (+10/-5) Y=890 (+10/-5)	BLAB X= 1890 (+10/-5) Y=990 (+10/-5)
2000	BM8B X= 1990 (+10/-5) Y=790 (+10/-5)	BM9B X= 1990 (+10/-5) Y=890 (+10/-5)	BMAB X= 1990 (+10/-5) Y=990 (+10/-5)	

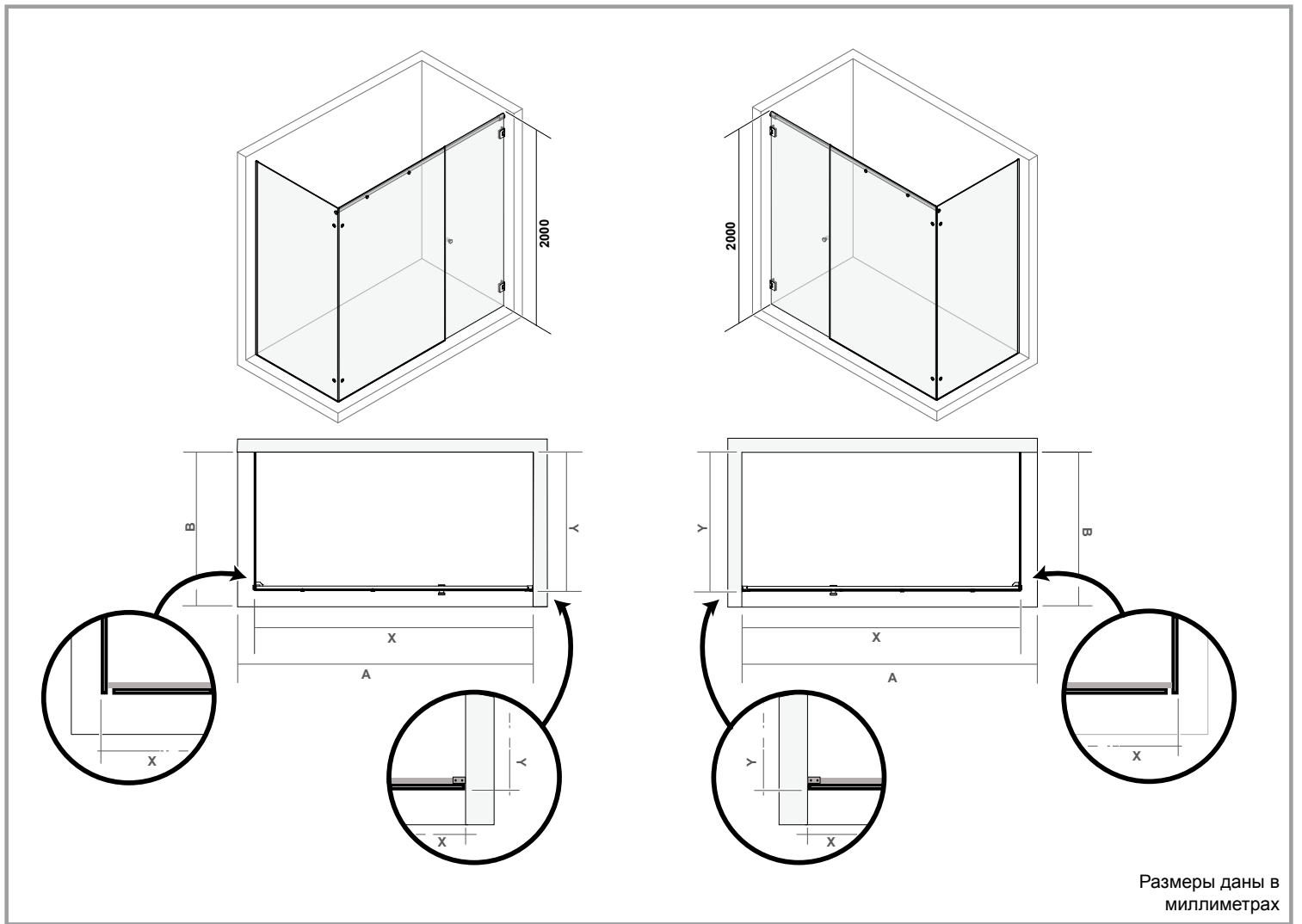

Размеры даны в миллиметрах

ART. B--B----		
Вес нетто, Kg.	Вес в упакованном виде, Kg.	Объем в упакованном виде, m ³
min. 62 - max. 118	min. 64 - max. 186	min. 1 - max. 3,5

		B		
		800	900	1000
A	800	B88B X= 790 (+5/-0) Y=790 (+10/-5)	B89B X= 790 (+5/-0) Y=890 (+10/-5)	B8AB X= 790 (+5/-0) Y=990 (+10/-5)
	900	B98B X= 890 (+10/-5) Y=790 (+10/-5)	B99B X= 890 (+10/-5) Y=890 (+10/-5)	B9AB X= 890 (+10/-5) Y=990 (+10/-5)
	1000	BA8B X= 980 (+10/-5) Y=790 (+10/-5)	BA9B X= 990 (+10/-5) Y=890 (+10/-5)	BAAB X= 990 (+10/-5) Y=990 (+10/-5)
	1100	BB8B X= 1090 (+10/-5) Y=790 (+10/-5)	BB9B X= 1090 (+10/-5) Y=890 (+10/-5)	BBAB X= 1090 (+10/-5) Y=990 (+10/-5)
	1200	BC8B X= 1190 (+10/-5) Y=790 (+10/-5)	BC9B X= 1190 (+10/-5) Y=890 (+10/-5)	BCAB X= 1190 (+10/-5) Y=990 (+10/-5)
	1300	BD8B X= 1290 (+10/-5) Y=790 (+10/-5)	BD9B X= 1290 (+10/-5) Y=890 (+10/-5)	BDAB X= 1290 (+10/-5) Y=990 (+10/-5)
	1400	BE8B X= 1390 (+10/-5) Y=790 (+10/-5)	BE9B X= 1390 (+10/-5) Y=890 (+10/-5)	BEAB X= 1390 (+10/-5) Y=990 (+10/-5)
	1500	BF8B X= 1490 (+10/-5) Y=790 (+10/-5)	BF9B X= 1490 (+10/-5) Y=890 (+10/-5)	BFAB X= 1490 (+10/-5) Y=990 (+10/-5)
	1600	BG8B X= 1590 (+10/-5) Y=790 (+10/-5)	BG9B X= 1590 (+10/-5) Y=890 (+10/-5)	BGAB X= 1590 (+10/-5) Y=990 (+10/-5)
	1700	BH8B X= 1690 (+10/-5) Y=790 (+10/-5)	BH9B X= 1690 (+10/-5) Y=890 (+10/-5)	BHAB X= 1690 (+10/-5) Y=990 (+10/-5)
	1800	BI8B X= 1790 (+10/-5) Y=790 (+10/-5)	BI9B X= 1790 (+10/-5) Y=890 (+10/-5)	BIAB X= 1790 (+10/-5) Y=990 (+10/-5)
	1900	BL8B X= 1890 (+10/-5) Y=790 (+10/-5)	BL9B X= 1890 (+10/-5) Y=890 (+10/-5)	BLAB X= 1890 (+10/-5) Y=990 (+10/-5)
2000	BM8B X= 1990 (+10/-5) Y=790 (+10/-5)	BM9B X= 1990 (+10/-5) Y=890 (+10/-5)	BMAB X= 1990 (+10/-5) Y=990 (+10/-5)	