

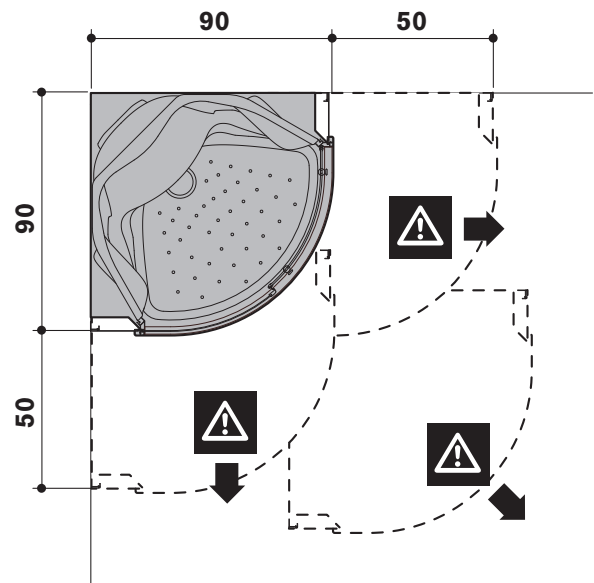

Allegare ai testi di pag.3 e 4 • This sheet to be with texts on pages 5 and 6  
 Fiche à associer aux textes des pages 7 et 8 • Dieses Datenblatt muß vom Text von S.9-10  
 Ficha a unirse a textos pág.11 y 12 • Esta ficha com textos pág.13 e 14

# FlexaThema ROUND

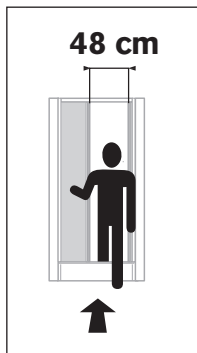
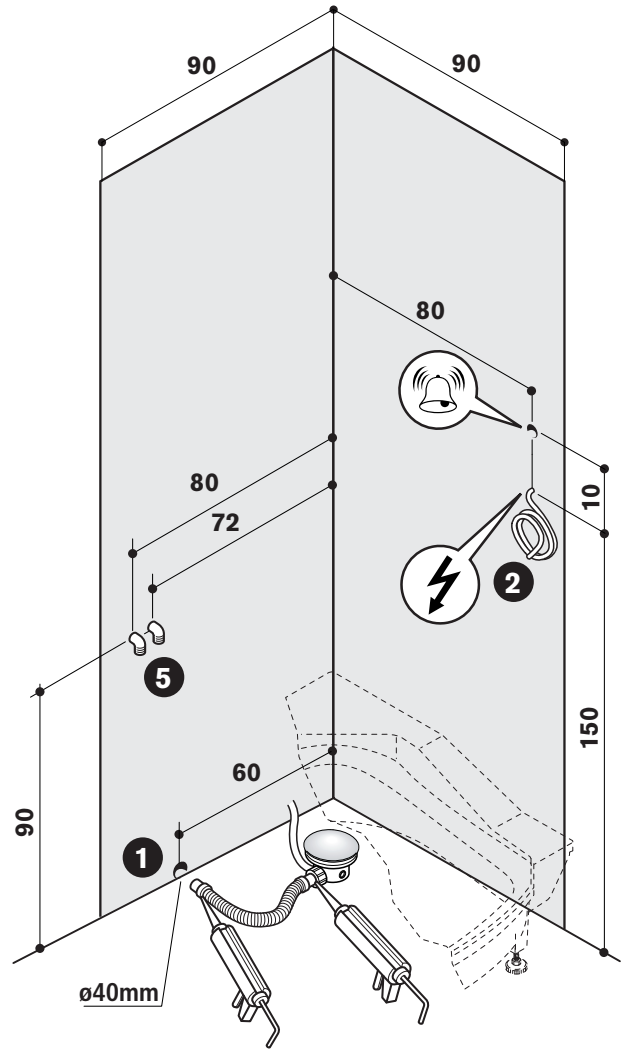
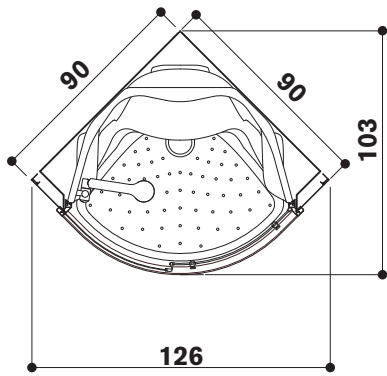
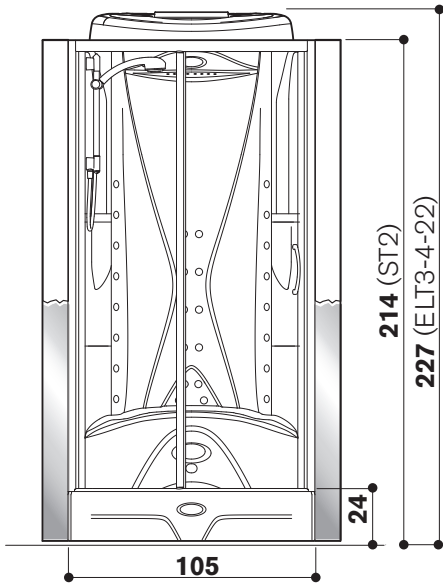

**ZONA LIBERA • ACCESS SPACE  
 BANDE LIBRE • FREIRAUM  
 ESPACIO LIBRE • ESPAÇO LIVRE**





**CARATTERISTICHE IDRAULICHE • HYDRAULIC SPECIFICATIONS • CARACTERISTIQUES HYDRAULIQUES**

**HYDRAULIK-ANGABEN • CARACTERISTICAS HIDRAULICAS • CARACTERÍSTICAS HIDRÁULICAS**

PRESSIONE DI ESERCIZIO • OPERATING PRESSURE • PRESSION DE SERVICE  
 BETRIEBSDRUCK • PRESIÓN DE FUNCION. • PRESSÃO DE FUNCION.....bar

PRESSIONE OTTIMALE • OPTIMUM PRESSURE • PRESSION OPTIMAL  
 OPTIMALER WASSERDRUCK • PRESIÓN ÓPTIMAL • PRESSÃO OPTIMAL.....bar

CONSUMO D'ACQUA • WATER CAPACITY • CONSOMMATION D'EAU  
 WASSERVERBRAUCH • CONSUMO DE AGUA • CONSUMO DE ÁGUA.....l/min (MAX)

BOCCHETTE IDRO • WHIRLPOOL FITTINGS • BUSES HYDROMASSAGE  
 ANZAHL MASSAGEDÜSEN • BOQUILLAS HIDROMASAJE • JACTOS DE HIDROMASSAGEM

**COLLEGAMENTI • CONNECTIONS • RACCORDEMENTS**  
**ANSCHLÜSSE • CONEXIONES • CONEXÃO**

ACQUA CALDA/FREDDA • HOT/COLD WATER • EAU CHAUDE/FROIDE  
 KALT/WARMWASSER • AGUA CALIENTE/FRIA • ÁGUA QUENTE/FRIA.....Ø

SCARICO A PARETE • WALL DRAINAGE • ÉCOULEMENT AU SOL  
 ABFLUSSROHR AM BODEN • DESAGUADERO EN SUELO • DESCARGA NO PAVIMENTO.....Ø

| ST2                     | ELT3                    | ELT4                    | ELT22                   |
|-------------------------|-------------------------|-------------------------|-------------------------|
| •                       | •                       | •                       | •                       |
| <b>2+3</b>              | <b>2+3</b>              | <b>2+3</b>              | <b>2+3</b>              |
| <b>14<sup>(1)</sup></b> | <b>13<sup>(2)</sup></b> | <b>13<sup>(2)</sup></b> | <b>13<sup>(2)</sup></b> |
| <b>8 + 4</b>            | <b>16 + 4</b>           | <b>16 + 8</b>           | <b>16 + 8</b>           |
| <b>1/2"</b>             | <b>1/2"</b>             | <b>1/2"</b>             | <b>1/2"</b>             |
| <b>40 mm</b>            | <b>40 mm</b>            | <b>40 mm</b>            | <b>40 mm</b>            |

• min 1,5 - max 5 (min 21 psi - max 70 psi / 150 kPa min - 500 kPa max)

- (1) idrogetti (a 2,5 bar) • hydro-nozzles (at 2,5 bar) • buses hydro (à 2,5 bar) • Massagedüsen (hat 2,5 bar) • boquillas de hidro (a 2,5 bar) • bocas hidro (a 2,5 bar)  
 (2) soffione doccia (a 2,5 bar) • shower head (at 2,5 bar) • pomme de douche (à 2,5 bar)  
 Kopfbrause (hat 2,5 bar) • rociador de la ducha (a 2,5 bar) • chuveiro duche (a 2,5 bar)

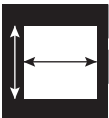

**CARATTERISTICHE DIMENSIONALI • WEIGHT AND DIMENSIONS • DIMENSIONS & POIDS**

**MASSE UND GEWICHTE • CARACTERISTICAS DIMENSIONALES • DIMENSÕES E PESOS**

LxWxH ..... cm

PESO NETTO • NET WEIGHT • POIDS NET • NETTOGEW. • NETO • LÍQUIDO ....~ kg

PESO DI SPEDIZIONE • SHIPPING WEIGHT • POIDS À L'EXPÉDITION  
 VERSANDGEWICHT • PESO DE EXPEDICIÓN • PESO DE EXPEDIÇÃO .....~ kg

VOLUME DI SPEDIZIONE • SHIPPING VOLUME • VOLUME À L'EXPÉDITION  
 VERSANDVOLUMEN • VOLUMEN DE EXPEDICIÓN • VOLUME DE EXPEDIÇÃO .....~ m<sup>3</sup>

IMBALLO • PACKAGE • EMBALLAGE • VERPACKUNG • EMBAL. • EMBAL.....cm

| ST2                        | ELT3                       | ELT4                       | ELT22                      |
|----------------------------|----------------------------|----------------------------|----------------------------|
| <b>90x90x214</b>           | <b>90x90x227</b>           | <b>90x90x227</b>           | <b>90x90x227</b>           |
| <b>110</b>                 | <b>121</b>                 | <b>121</b>                 | <b>123</b>                 |
| <b>175</b>                 | <b>186</b>                 | <b>186</b>                 | <b>188</b>                 |
| <b>3,68</b>                | <b>3,68</b>                | <b>3,68</b>                | <b>3,68</b>                |
| <b>A+B+C<sup>(x)</sup></b> | <b>A+B+C<sup>(x)</sup></b> | <b>A+B+C<sup>(x)</sup></b> | <b>A+B+C<sup>(x)</sup></b> |

- (x) A: parete • panele • panneau • Paneel • parede • parede: **206x97x93 - kg 44/81 (ST2) • kg 50/87 (ELT3/4) • kg 52/89 (ELT22)**  
 B: piatto doccia • shower tray • plateau de douche • Duschwanne • plato de ducha • fundo do ducha: **109x107x38 - kg 13/19 (ST2) • kg 18/24 (ELT3, 4, 22)**  
 C: cristalli • glasses • vitres • Gläse • cristales • cristais: **220x112x48 - kg 53/75**



**CARATTERISTICHE ELETTRICHE • ELECTRIC SPECIFICATIONS • CARACTERISTIQUES ELECTRIQUES**

**ELEKTRO-ANGABEN • CARACTERISTICAS ELECTRICAS • CARACTERÍSTICAS ELÉCTRICAS**

VOLT.....V

HERTZ.....Hz

AMPÈRE (BAGNO TURCO) • (STEAM BATH) • (HAMMAM) • (DAMPFBAD) • (BAÑO TURCO) • (BANHO TURCO) .....A

kW (BAGNO TURCO) • (STEAM BATH) • (BAIN TURC) • (DAMPFBAD) • (BAÑO TURCO) • (BANHO TURCO) .....kW

| ST2 | ELT3                        | ELT4                        | ELT22                       |
|-----|-----------------------------|-----------------------------|-----------------------------|
| -   | <b>220/240</b>              | <b>220/240</b>              | <b>220/240</b>              |
| -   | <b>50</b>                   | <b>50</b>                   | <b>50</b>                   |
| -   | <b>11<sup>(k)</sup></b>     | <b>11<sup>(k)</sup></b>     | <b>11<sup>(k)</sup></b>     |
| -   | <b>2,5<sup>(j)(k)</sup></b> | <b>2,5<sup>(j)(k)</sup></b> | <b>2,5<sup>(j)(k)</sup></b> |

(j) potenza assorbita • power absorption • puissance absorbée • Leistungsaufnahme • potencia absorbida • potência absorvida **MAX 2,5 kW**

(k) a 230 V • at 230 V • à 230 V • hat 230 V • a 230 V • a 230 V